

Penn State Berks



Campus Exterior Architectural Plan
July 2007

Contents

Introduction and Purpose

Existing Conditions Inventory

Improvement Recommendations

Introduction and purpose

Penn State's Mission:

Penn State is a multi-campus public land-grant university that improves the lives of the people of Pennsylvania, the nation, and the world through integrated, high-quality programs in teaching, research, and service.

To assist in achieving this mission, a Campus Exterior Architecture Plan, known as a CEAP, is developed to suggest ways to improve the exterior aesthetic qualities of campus with low-cost and easy-to-implement concepts that can have meaningful impacts. The CEAP is a planning tool that is an outgrowth of the campus master planning process.

The CEAP includes graphic and narrative descriptions of existing conditions on campus and approximately 15-20 improvement concepts. Positive features may also be identified as elements to emulate.

The improvement concepts are ranked or prioritized according to their visual impact and estimated cost. The concepts are not final designs. Further study and design are required prior to implementation.

Campus Map



Existing Conditions Inventory

Background:

A detailed site analysis, campus vision and future development strategy is fully documented in the campus master plan. In addition to the analysis performed during the master planning process, a more focused walking assessment of the campus exterior established the foundation for the recommendations and concepts contained in this CEAP document.

General Observations:

The campus is situated in a transition zone between the intensely active highway and commercial development areas on the southern boundary to the serene leisurely quality of the Gring's Mill Recreation Area and Tulpehocken Creek to the north. Once you leave your vehicle in the abundant though sterile parking lots and enter the campus on foot, the comfortable human scale of the buildings and open space engender a nurturing, collegiate awareness. The buildings and grounds are well maintained and demonstrate a cared for image to students, faculty and staff as well as the general public.

The academic core of campus has evolved with respect for a drainageway in the topography and preservation of wooded hillsides at the perimeter. High quality student housing has been developed in a distinctly inclusive zone separated from the academic core. This neighborhood atmosphere enhances all aspects of resident student life. Conversely, administrative functions are incongruously isolated at the western edge of the developed portion of campus .

Stands of mature trees are abundant providing opportunities for passive use as well as defining the administrative, academic and housing zones. Open space has also been respected in the development of the campus. Improved outdoor gathering spaces for organized activities are limited. The creative and inventive aspects of higher education are showcased extensively through a significant number of public art installations.

Pedestrian circulation in the campus core is functional however the opportunity exists to modify alignments and materials to unify buildings and better organize exterior space. In addition, maintenance, operational and environmental efficiencies could be realized by consolidating and reducing unnecessary, redundant and excessive paved surfaces. Parking facilities are adequate and suitably located on the campus perimeter minimizing conflicts with pedestrians. The presence of a highly traffic service corridor through the heart of the academic core poses hazards to pedestrians. Signage and wayfinding at the campus should be enhanced and standardized.



Architecture

Existing Conditions Inventory

Major architectural modifications, additions, and new construction are beyond the scope of this CEAP. However, the aesthetic character of campus is defined to a great extent by the structures that comprised it. Brick, block, stone and painted "stucco-like" materials characterize the contemporary structures on campus. Administration and Maintenance & Operations functions are housed in colonial style stone structures. An eclectic mix of architectural styles has developed across the campus.



Site Furnishings

Existing Conditions Inventory

Benches and trash receptacles across the campus are varied in design, color and material. Furnishings are in good repair on the whole. It is recommended that a standard design for furnishings be selected that will aid in unifying the campus aesthetic.

In addition to aesthetic appropriateness, the longevity and maintenance of site furnishings should be considered when specifying.



Lighting

Existing Conditions Inventory

A variety of exterior lighting fixture types are present on campus. As with site furnishings, it is recommended that design standards for parking lot/roadway and pedestrian site lighting be identified and implemented across campus. Full Cut-off luminaires that mitigate light pollution should be used. Metal Halide lamps on pedestrian walkways is recommended.



Signage

Existing Conditions Inventory

Consistent design and placement of signage is key to a unified aesthetic as well as an intuitive and clear means of way finding. Campus maps are present and partially conform to the University standard. Building identification signs are consistent stylistically though difficult to read in some cases.

Entrance signage should be upgraded to reflect the campus mark and establish a clear entrance.

It is recommended that the PSU sign standards be implemented at the campus.

www.opp.psu.edu/stdn/signage/index.html

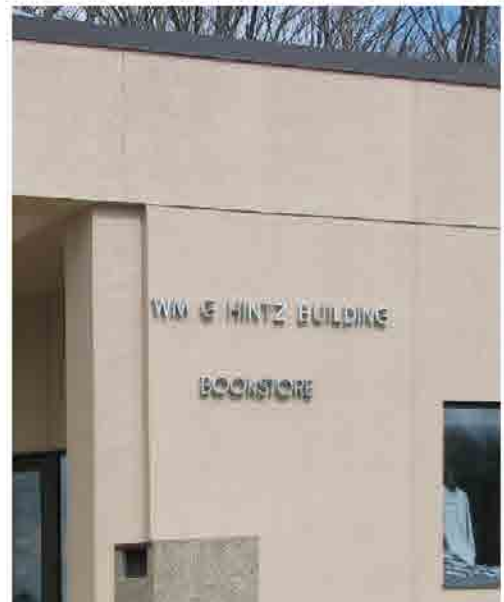

Landscape

Existing Conditions Inventory

The landscape aesthetic of the campus is characterized by many large, quality specimen trees. Ornamental plantings are conservative and well maintained. Mature wooded areas should continue be protected from development. Some invasive plant species should be eradicated. Opportunities exist for the limited use of perennial and annual flower color. Turf areas appear to be weed-free and well maintained.

Formal and informal gathering spaces exist though opportunities for additional varied outdoor gathering spaces is noted.



Pedestrian Circulation

Existing Conditions Inventory

The system of pedestrian walkways through and around campus appear to have evolved based on pedestrian desire. There are redundant walkways in some areas and absence of improved walks in others resulting in "cow paths". The use of concrete in lieu of asphalt for walkway surfacing is recommended. Conflicts with vehicular circulation are noted.



Unique Features

Existing Conditions Inventory



The extensive display of public art is noted.

The campus is encouraged to continue diligent maintenance of existing works and the sites they occupy as well as adding to the collection as appropriate. Preparation of a walking tour describing the various works is recommended.



The grouping of colonial style stone buildings including the Janssen Conference Center are a unique feature on the campus.



Improvement Concepts

The following figures describe and illustrate possible solutions to specific aesthetic and functional shortcomings on campus, most of which are addressable through the CEAP program. In addition to the recommendations that follow, there are routine maintenance tasks that will enhance the aesthetic appeal of campus. Suggestions include:

- ▶ Mulch landscape beds annually
- ▶ Eradicate weeds and other invasive vegetation
- ▶ Fertilize lawn areas
- ▶ Focus the use of annual and perennial plantings
- ▶ Seal and re-stripe paved areas

An implementation priority matrix has been prepared that lists improvement projects and recommends the order in which the concepts/projects could be executed. The implementation ranking is intended as a guideline for realizing the most significant impacts early in the plan implementation.

Location specific concepts/projects are keyed to the map with numbers corresponding to the listing on the matrix at the end of this report.

Perkins Service Area & Rooftop Mechanical Equipment

Improvement Recommendation

The service dock area at the southeast corner of the Perkins Student Center is located at the intersection of a primary pedestrian walkway between the academic core of campus and student housing. The rooftop mechanical equipment and loading dock are plainly visible to passers-by.

Recommend that the equipment be screened like other equipment on the west side of the building. In addition, a screen panel could be erected at the dock to hide other unsightly utility equipment as well as providing a place to store temporary delivery paraphernalia. The existing electrical transformer and building entrance doors should be painted to match the screen panel.



Existing



Existing Screen

Screen roof top mechanical equipment

- Paint doors to match screen panels
- Store pallets and other dock equipment behind new screen panel
- Paint transformer to match



After

Site Furnishings Improvement Recommendation



Site furnishings designed in a style “family” are aesthetically unifying. The examples shown here will compliment the contemporary architectural style present on the campus. Powder coated metal is attractive, comfortable and durable.

Planters should be appropriately sized for the space they occupy and be constructed of durable, quality material.

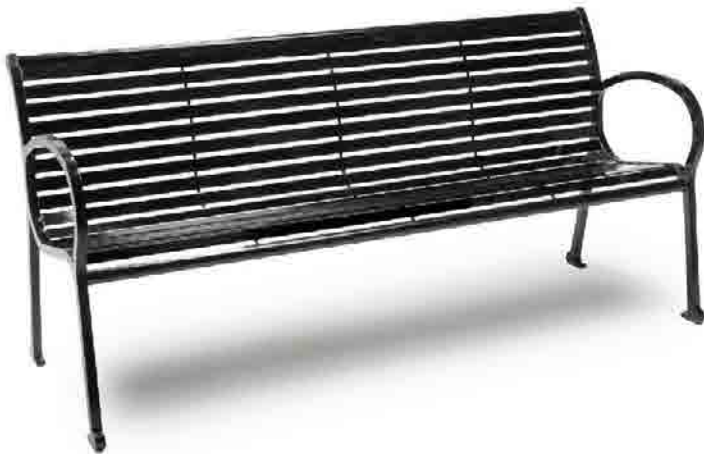

3 Lighting

Improvement Recommendation

Replacement of any antiquated, inefficient pedestrian walkway and parking lot lighting is recommended.

Metal halide lamps in cut-off luminaires mounted to poles are recommended for pedestrian walkways.

High pressure sodium lamping is acceptable for parking lot lights. Color/finish for all fixtures should be consistent campus wide. Avoid the use of bollards due to vulnerability to snow removal operations and vandalism. The two types illustrated here exist on campus and are recommended for campus wide installation as new projects or replacement opportunities arise.



Parking Lot/Roadway Light



Site Light

4A Signage

Improvement Recommendation

A consistent, quality graphic identity across the entire Penn State system is vital to conveying a unified image to the public. Detailed editorial, and graphic standards for use of the Penn State mark in varying sign applications have been developed.

Reference documents can be found on the internet at:

http://publications.psu.edu/graph_ident_system/graphunivmk.html

html

http://www.opp.psu.edu/construction/standards/signage/penn_State_Signage_Standards_Manual.pdf

In addition, there is a standing review committee within the Office of Physical Plant at University Park charged with review of signage proposals.

Recommend an assessment of all campus signage to develop a plan for upgrading the directional and building identification signs campus wide.

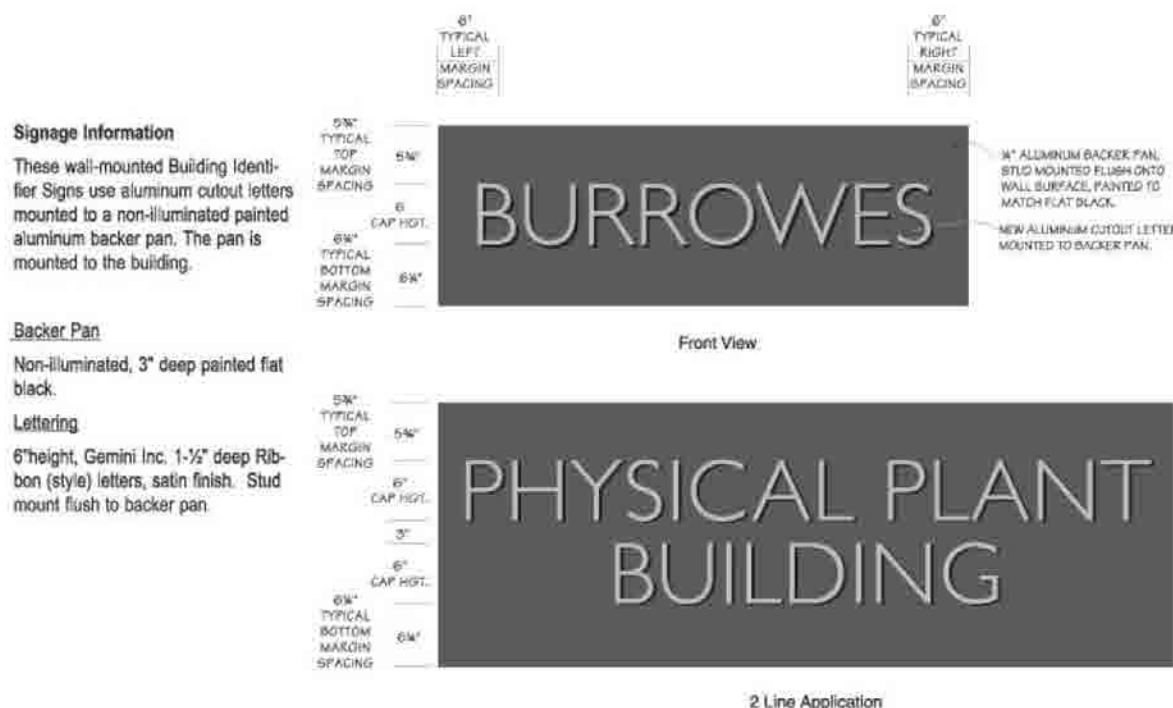

Building Identification Sign



Directional signage needs should be assessed and a plan prepared for implementing standardized graphics.

Existing Directional Sign

Signage Information

These Vehicular Directional Signs, located along interior campus roads, are smaller, leaner in construction, and less expensive than the perimeter masonry base signs.

These non-illuminated painted aluminum signs use removable and changeable individual panels with a non-reflective background and reflective vinyl copy and graphics. The sign face measures 3'-6" wide by 2'-8" tall.

The typeface is Univers 67 Condensed Bold.

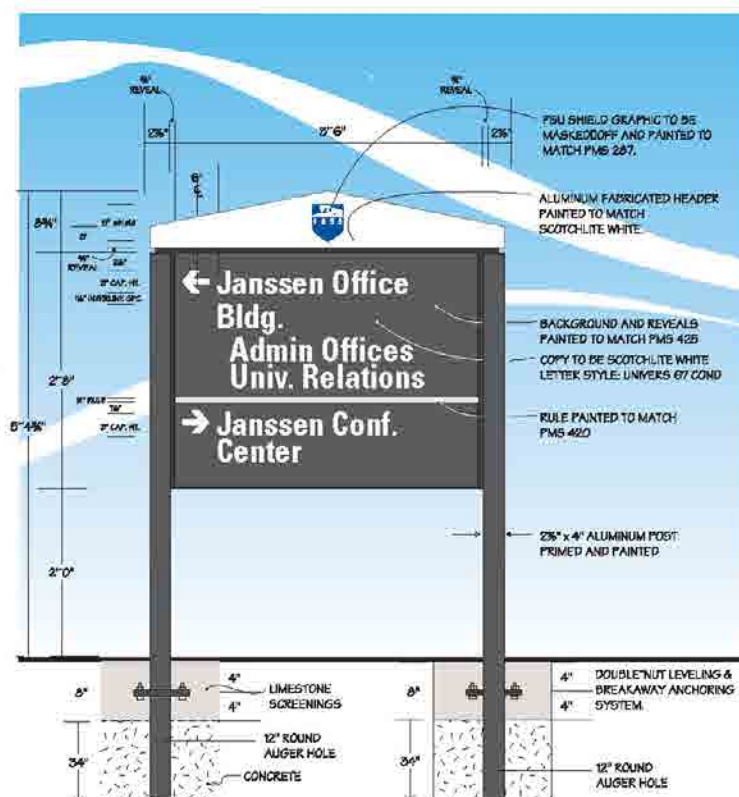

Directional Sign

2 Line Application

4B Signage

Signage Information

These Parking Lot Identification Signs are designed to distinguish the various parking categories on the campus, and clearly specify which permits are valid in each parking area.

These non-illuminated painted aluminum signs use vinyl reflective and non-reflective backgrounds and reflective vinyl copy and graphics. The sign face is mounted to painted Unistrut knockout posts.

The typefaces are Univers 67 Condensed Bold and Univers 57 Condensed.

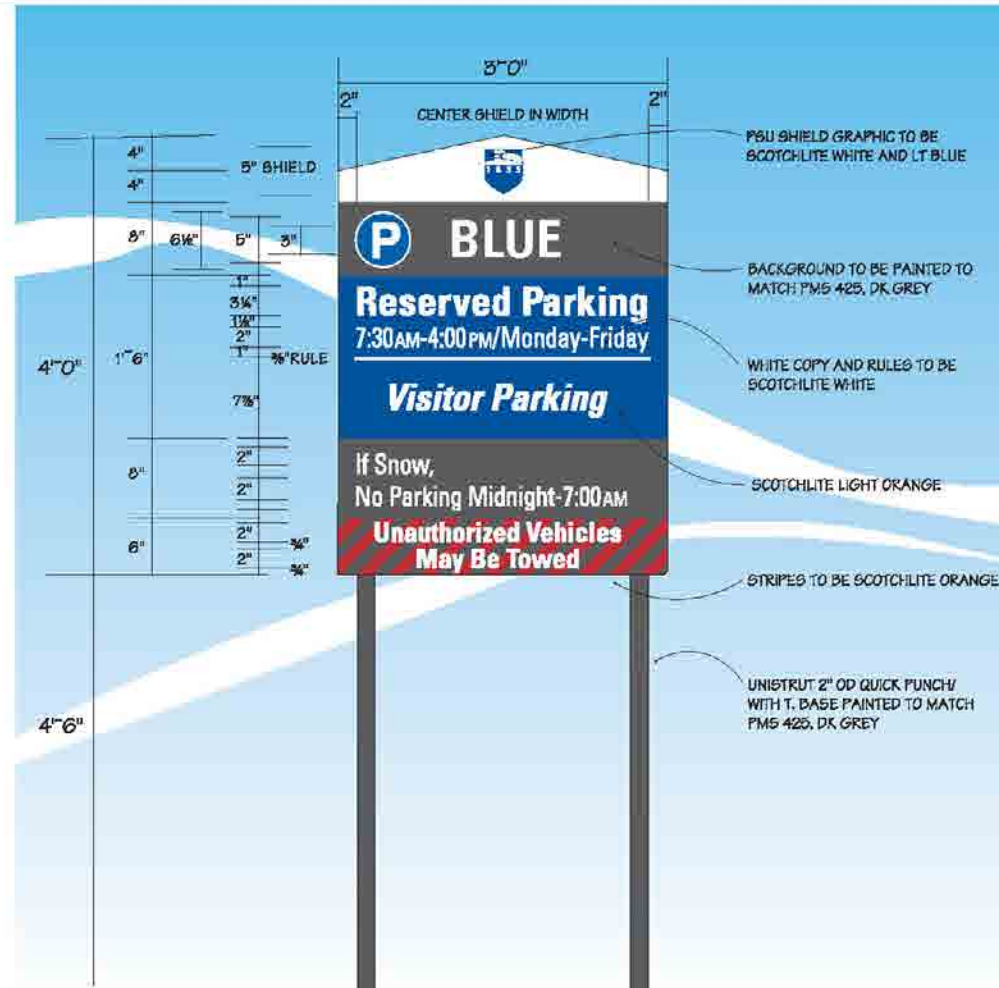

Improvement Recommendation

- Existing parking regulatory signage is difficult to interpret and may be unenforceable.
- Recommend a comprehensive parking lot signage upgrade to clearly delineate regulated areas.
- Parking regulation signs should be removed from primary campus entrances.
- Location, size and design of campus maps should be included in the signage assessment.



Existing Campus Map



Campus Map



Signature Mark for Penn State Berks

http://publications.psu.edu/graph_ident_system/

graphunivmk.html



Existing Campus Sign

Campus Entrance Sign ^{4C}

Improvement Recommendation

The primary campus identification sign at Broadcasting Road is insufficient in size, scale and quality to appropriately announce the campus.

Propose the development of a new monument size such as the one illustrated herein. The Berks campus identifier is shown in its correct proportion and graphic style.

The stone base is intended to recall native building materials of Berks County with a contemporary refined design.

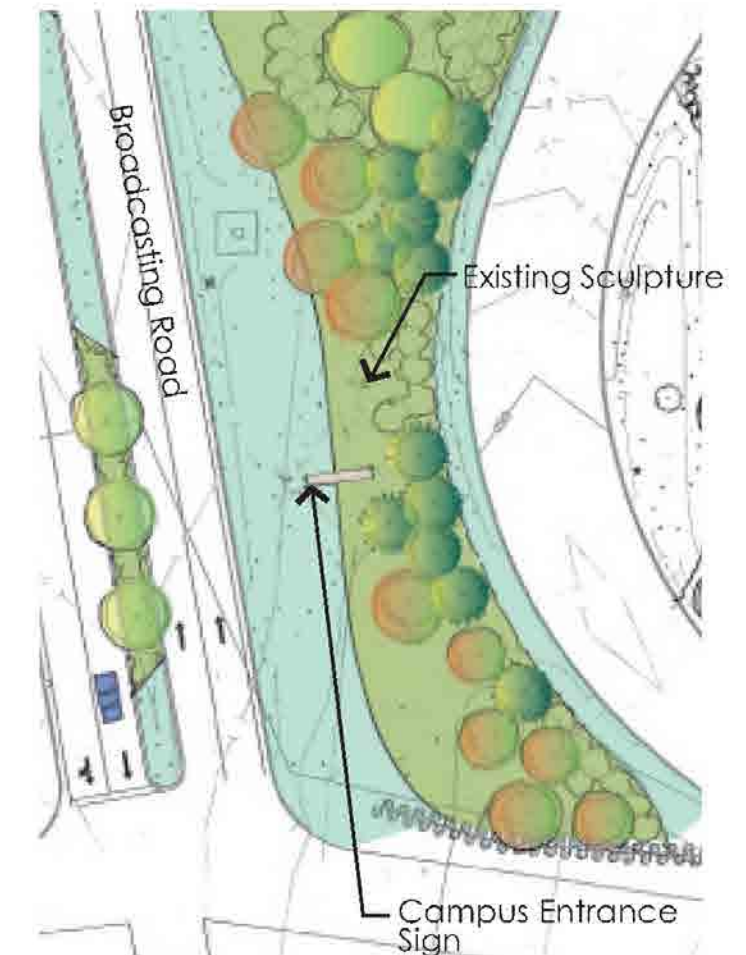

4D

Existing Sign at Tulpehocken Road

Improvement Recommendation



Before

The existing campus identification sign along Tulpehocken Road should be updated to reflect the campus signature mark. In addition the masonry should be cleaned and repaired as necessary.

Provide an appropriate ornamental landscape planting to visually enhance this entrance to campus.



After

4E

Hintz Field Sign

Improvement Recommendation

Provide a directional sign at the Berkshire Boulevard entrance to the Hintz Athletic Complex. Locate the double-sided sign on the south side of the existing parking lot entrance.

Signage Information

These Vehicular Directional Signs, located along interior campus roads, are smaller, leaner in construction, and less expensive than the perimeter masonry base signs.

These non-illuminated painted aluminum signs use removable and changeable individual panels with a non-reflective background and reflective vinyl copy and graphics. The sign face measures 3'-6" wide by 1'-6" tall.

The typeface is Univers 67 Condensed Bold.

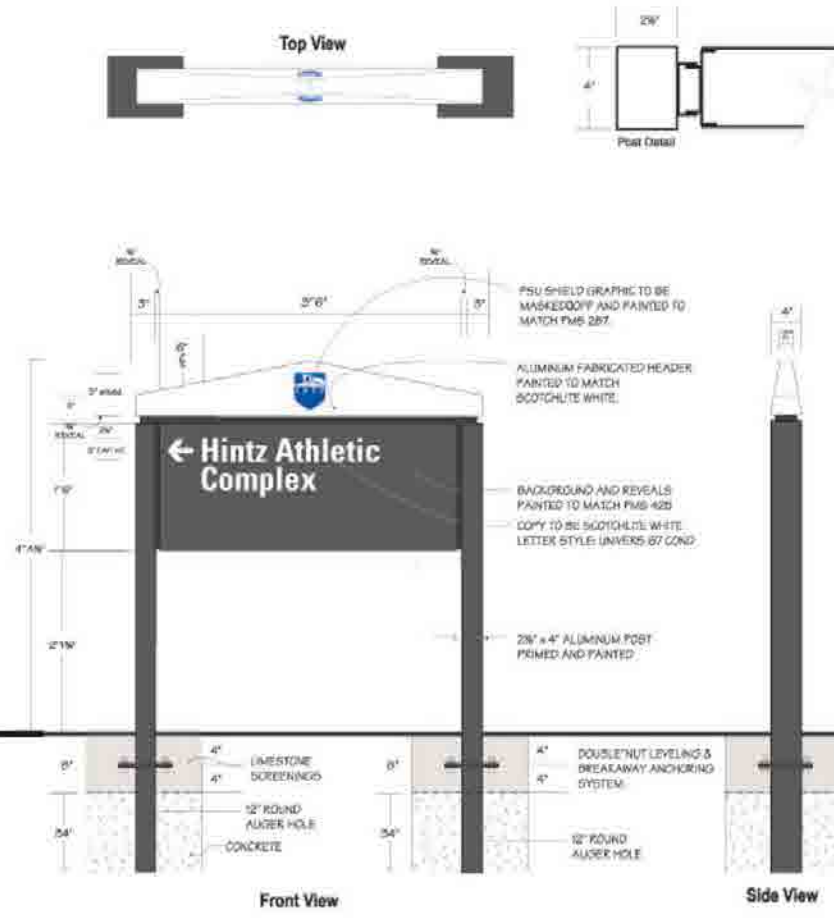

Entrance Landscape 5A

Improvement Recommendation

The landscape character of the main entrance to campus is unembellished and sparse. Roadways and parking lots constitute the first impressions of campus. Positive impact at this front door to the campus requires supplemental landscape plantings including trees and shrubs (evergreen and deciduous). Careful integration of new campus identification and directional signage is also a primary objective of this enhancement.

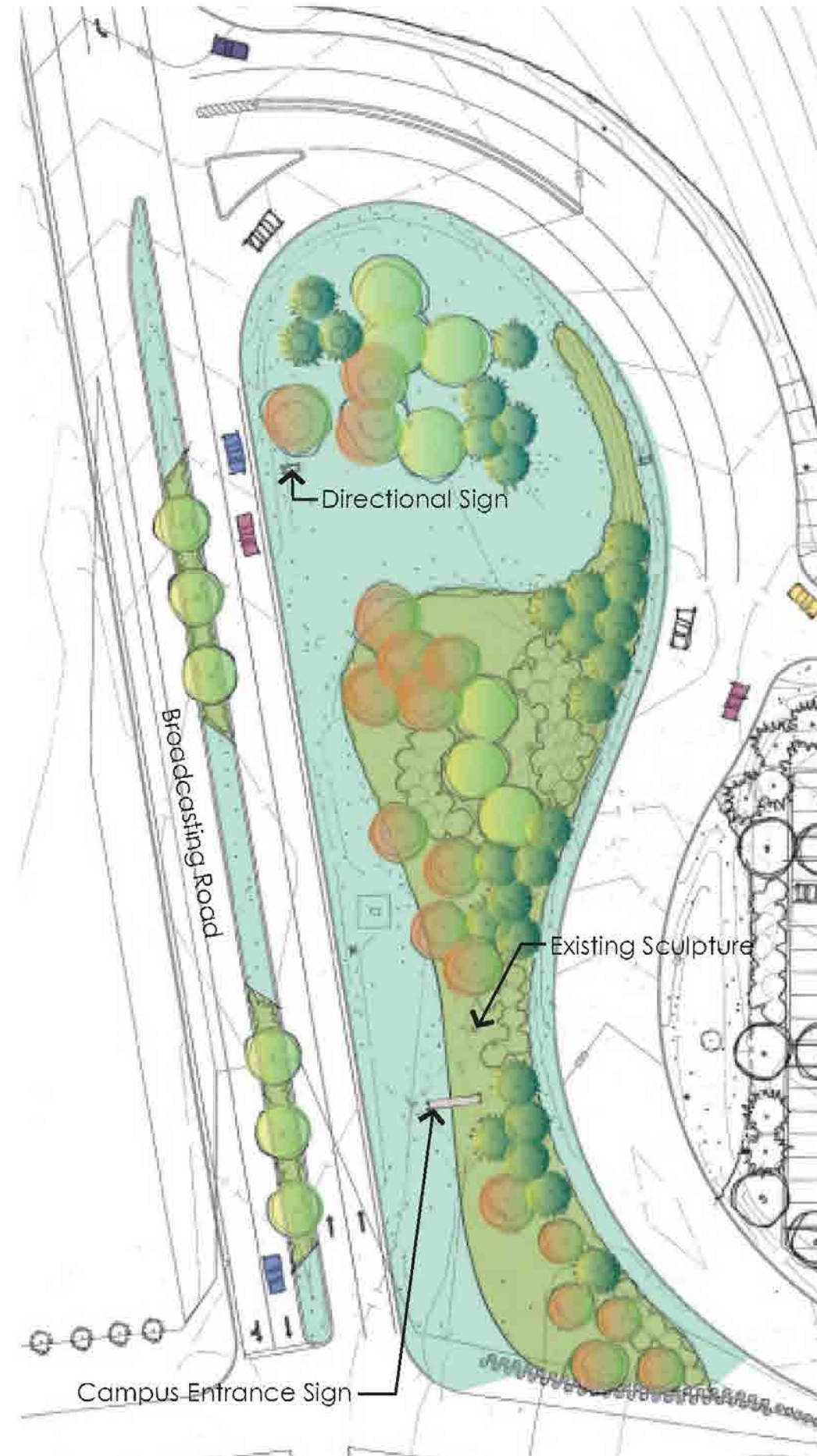

- Lawn
- Landscape
- Evergreen Tree
- Existing Deciduous Tree
- New Deciduous Tree



Existing view of campus from Broadcasting Road

Parking Lot 5B Landscape

Improvement Recommendation

Parking lots at the front door of campus are vast and unattractive. Visual quality can be improved through the installation of perimeter plantings and islands within the lots.



Existing Parking Lot at the campus entrance

Franco Amphitheater

5c

Improvement Recommendation

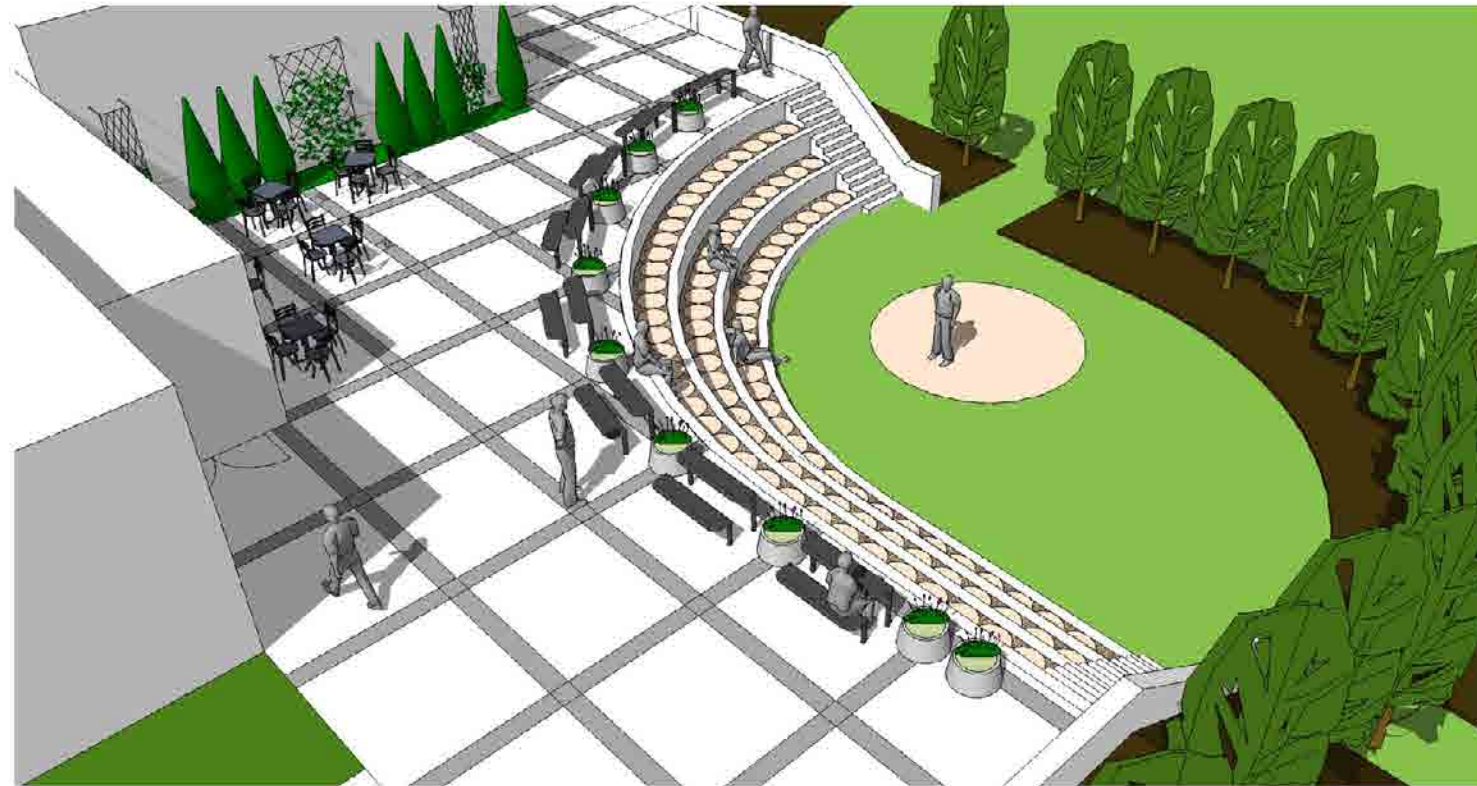

The existing amphitheater at Franco Building is uninviting and feels incomplete. There is minimal development of comfortable, usable seating. The terraced seat steps are turfed providing a poor quality seating surface.

Recommend the replacement of turf seat steps with a paver that will provide a clean, supportive surface for seating as well as eliminating a high maintenance surface.

The vertical drop at the uppermost edge of the amphitheater is unprotected which could result in a fall. Recommend the installation of bench seats with tables to provide the necessary barrier as well as usable seating.

The focal point of the amphitheater is undefined. Recommend the installation of a hard surfaced stage from which to entertain or instruct. A visual backdrop to the stage area is necessary to define the focus of the amphitheater.

Supplemental plantings and site furnishings on the patio above the amphitheater will make the space more attractive to casual users.



Existing Amphitheater



Perkins 5D Entrance Plaza

Improvement Recommendation

The main entrance to the Perkins Student Center is dominated by a barren asphalt parking surface. This space has the potential to be one of the most engaging and active gathering spaces on campus.

The concept involves the elimination of asphalt paving and replacement with an enhanced surface material to delineate and direct pedestrian movement as well as defining seating areas. The flow of pedestrian movement has been anticipated and accounted for in this scheme. Required accessible parking has been shifted off of the pedestrian space to an adjacent location.

The scheme preserves most of the existing mature trees at the building as well as proposing the addition of more shade giving and space defining vegetation.

The concept is grounded in an overall reorganization and reduction of existing paved walkways in core campus.

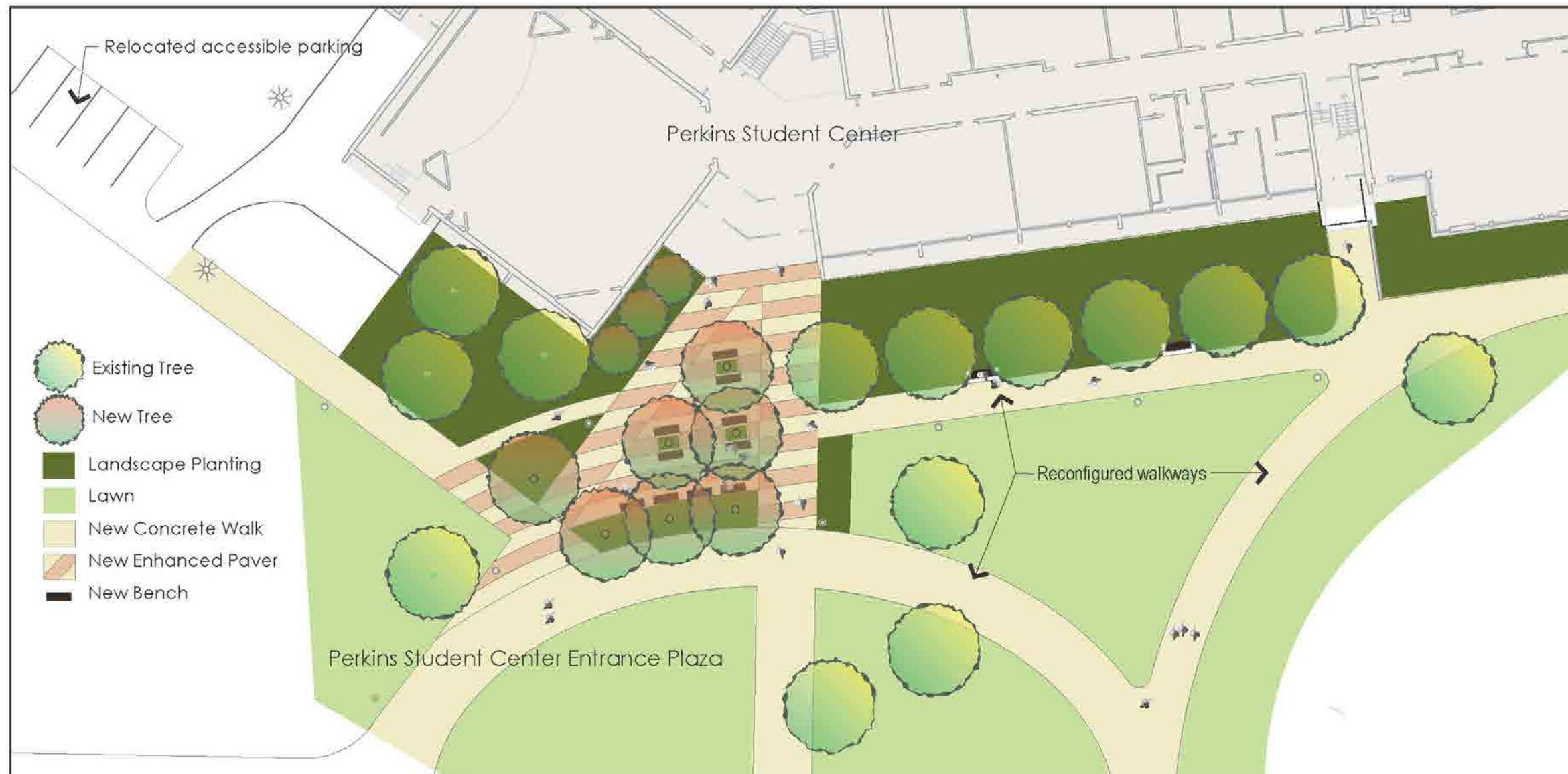

5E Post & Chain

Improvement Recommendation

Pedestrian movement through planting areas is not a major problem at the campus. However in those instances where users require persuasion to utilize designated walkways it is recommended that a simple post and chain barrier be installed.



Before - Pedestrian "desire lines" forming through landscape plantings



After - Place post and chain in strategic locations to discourage short cutting.



Existing



5F New Walkway

Improvement Recommendation

This primary access to the academic core from the housing area of campus is bisected by a service drive used to supply Perkins Student Center. Users have established a shortcut through the lawn.

Recommend the construction of a new walkway segment to connect the housing area to the rear of Perkins Student Center and beyond into campus. The connection will traverse a slope and tie into the existing drive opposite the northeast entrance to Perkins. Not only will this new connection make campus access more direct for some destinations but it will draw pedestrians away from the loading dock area where safety conflicts and aesthetic challenges exist.

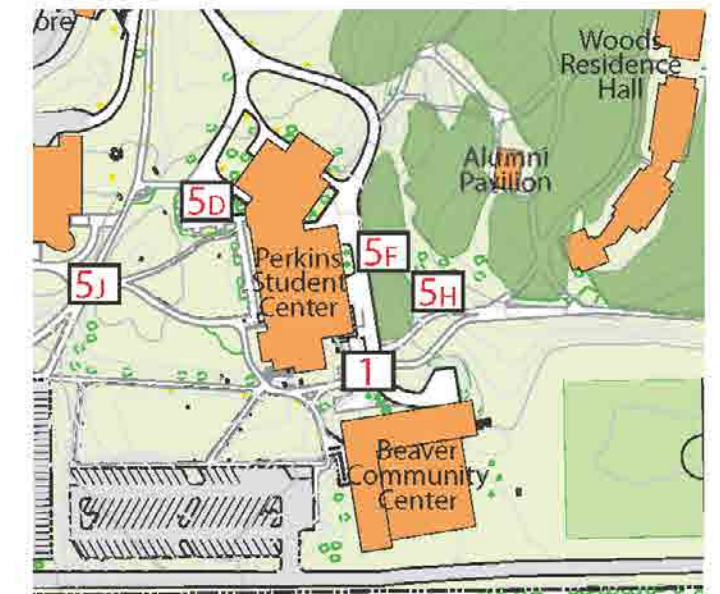

5G Walkway

Improvement Recommendation



Existing Condition

The existing pedestrian circulation network between Greenbriar and Sage Halls inadequately accommodates movements between the commuter parking lot and core campus. It is recommended that a segment of walkway be constructed to eliminate the existing short-cut through the turf area.

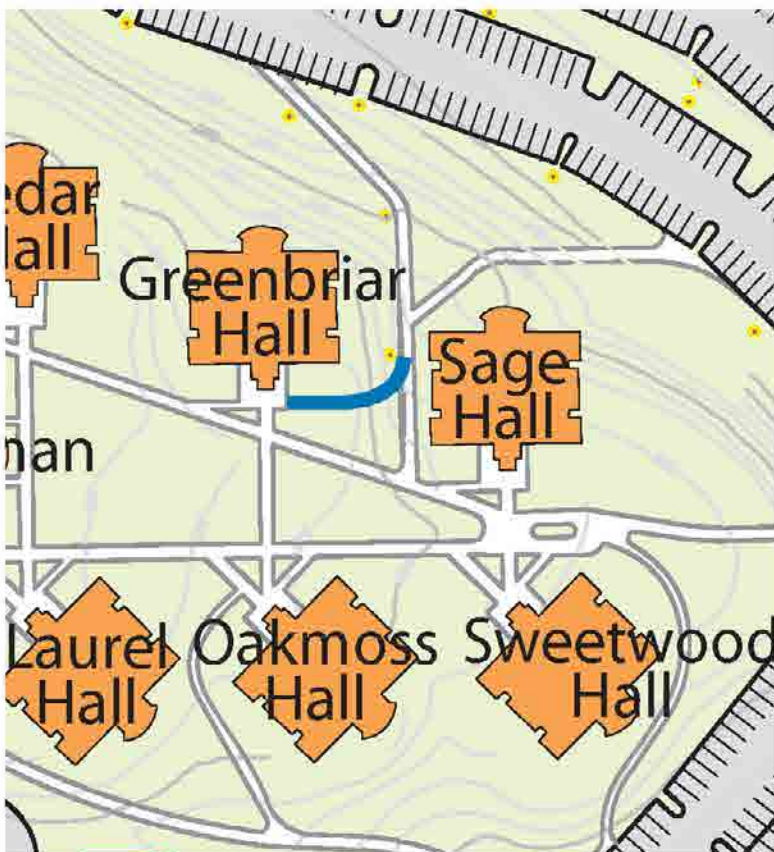

5H Dish Removal

Improvement Recommendation

The existing satellite dish located to the east of Perkins Student Center should be removed from the site.



5I Handrail

Improvement Recommendation



The existing site steps in the commuter portion of the Handwerk Road parking lot do not have code required handrails in place. It is recommended that this deficiency be corrected.

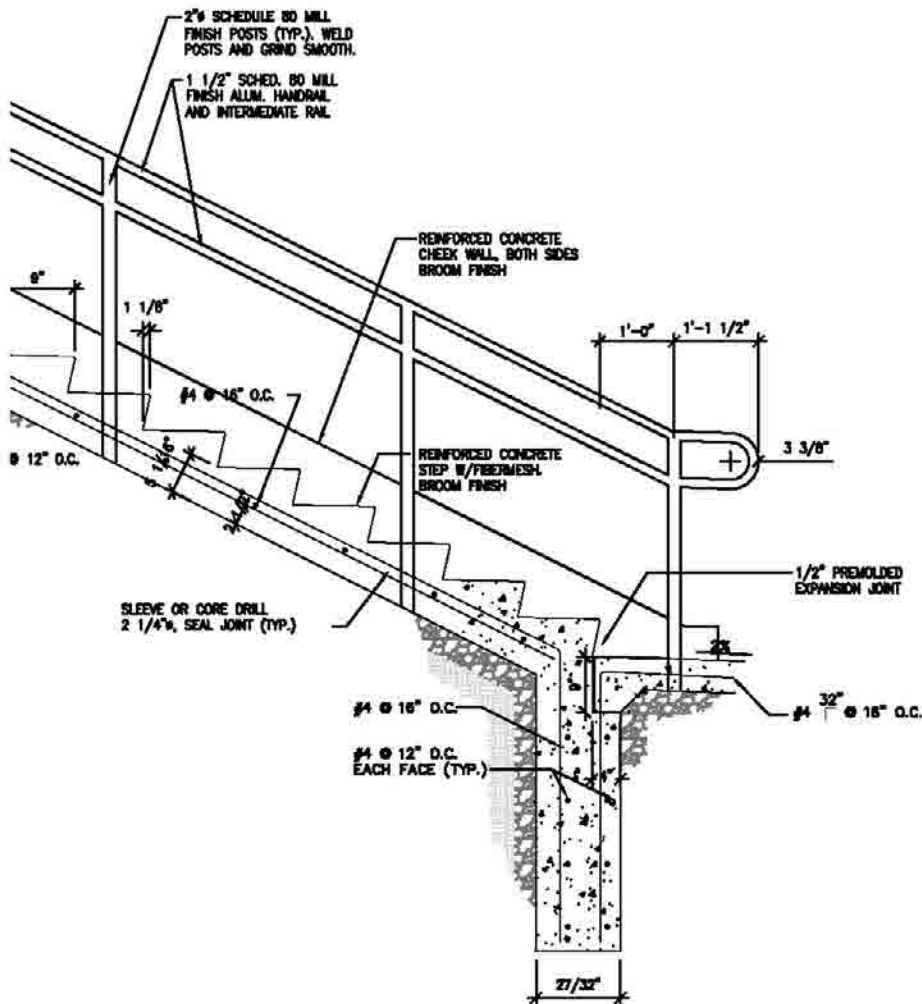



5J New Core Campus Walkway

Improvement Recommendation

The pedestrian walkway system in the core of campus lacks a cohesive underlying organization. Walkways are irregular in width and are unnecessarily redundant in some cases.

Recommend the replacement of walkways over time in a planned and organized fashion. The walkways should define outdoor spaces while at the same time providing direct, convenient routes between buildings. It is also recommended that sidewalks be constructed of concrete as opposed to the asphalt surfacing that prevails at the campus.

Existing trees of value should be preserved and integrated into the geometry of the walkway design where possible.

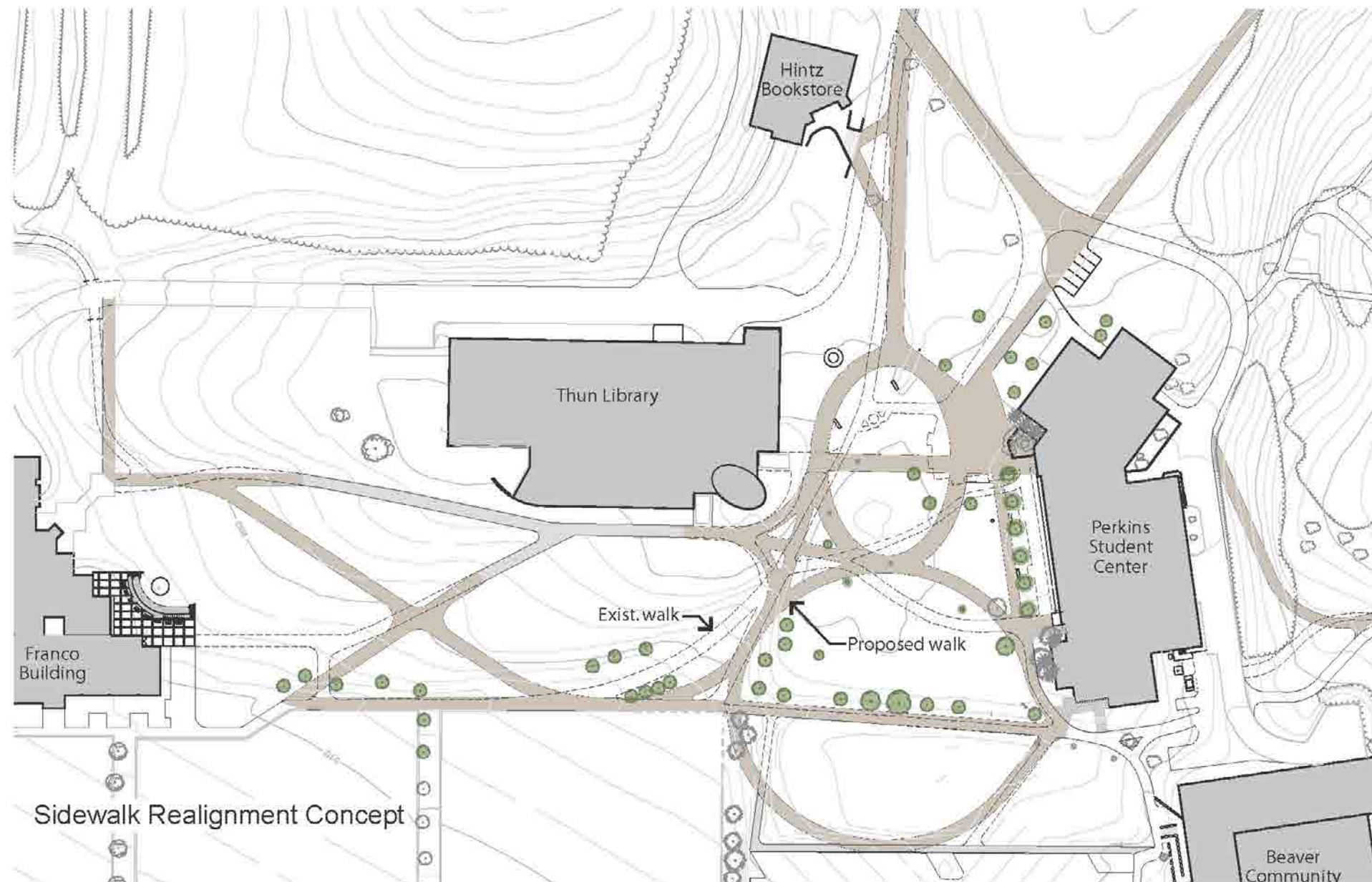

Sidewalk Realignment Concept

Project Key Map

Penn State Berks
 Campus Exterior Architectural Plan
 Project Prioritization Matrix
 June 2007

Proposed exterior improvement projects have been assessed with respect to the following criteria and assigned an implementation priority value.

Criteria include:

Visual Impact - degree to which the project improves the visual quality of the campus

Cost - level of capital investment required to implement the project (assumes no volunteer or donor contribution)

The projects with the highest numeric score should be given the highest priority for implementation

VISUAL IMPACT	COST
1 - Little or no impact	1 - Greater than \$25,000
2 - Minor Impact	2 - \$15,001 to \$25,000
3 - Moderate Impact	3 - \$5,001 to \$15,000
4 - Major Impact	

#	PROJECT	IMPACT				COST			SCORE
		1	2	3	4	1	2	3	
1	Perkins Loading Dock Screening				X	X			5
2	Site Furnishings (campus wide)				X	X			5
3	Lighting (campus wide)				X	X			5
4A	Signage (campus wide)				X	X			5
4B	Signage (campus wide)				X	X			5
4C	Campus Entrance Sign (Broadcasting Road)				X	X			
4D	Entrance Sign Renovation (Tulpehocked Road)			X		X			5
4E	Hintz Athletic Field Sign	X					X		5
5A	Campus Entrance Landscape				X	X			5
5B	Parking Lot Landscape				X	X			5
5C	Franco Amphitheater Enhancements				X	X			5
5D	Perkins Entrance Plaza				X	X			5
5E	Post & Chain (select locations)		X				X		6
5F	New Walkway at Perkins		X			X			6
5G	New Walkway at Greenbriar Hall		X			X			6
5H	Satellite Dish Removal		X				X		6
5I	New Handrail	X					X		5
5J	New Core Campus Sidewalks				X	X	X		5

2, 3, 4AB Campus wide

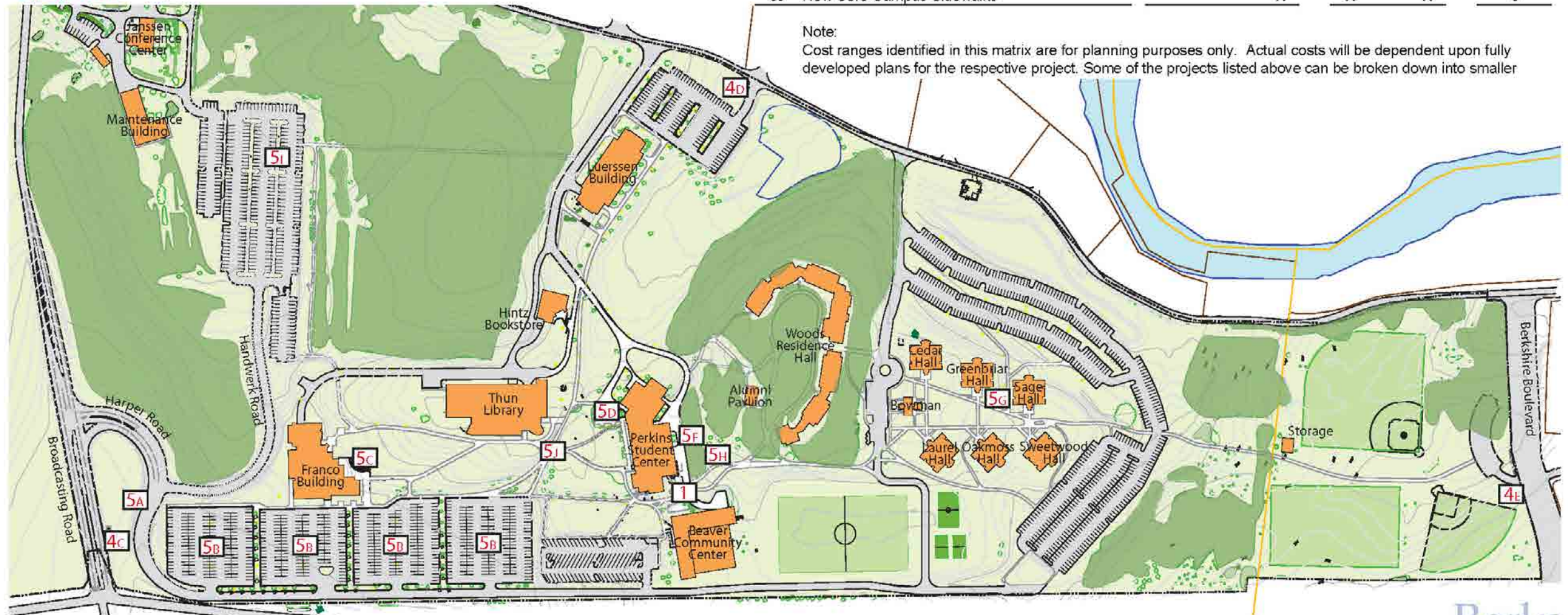

Note:
 Cost ranges identified in this matrix are for planning purposes only. Actual costs will be dependent upon fully developed plans for the respective project. Some of the projects listed above can be broken down into smaller